

KOSHIN

High Performance Submersible Pump OPERATION MANUAL < PX-55011 / 55022 / 55022A > < PXL-52511 / 52522 >

- Thank you for choosing Koshin Submersible Pump.
- This manual is prepared for your safety when operating pump. Please read carefully and comprehend fully before use. (Wrong usage could cause injury or death.)
- Please keep this manual handy for future reference.

PLEASE READ THIS MANUAL BEFORE OPERATION.

"ACCEPTABLE FOR INDOOR OR OUTDOOR USE" "SUBMERSIBLE PUMP"

⚠ CAUTION ⚠

Before use, please make sure to read the instruction manual.
Do not operate the pump out of water or insufficient water.

⚠ WARNING ⚠

Risk of electric shock. This pump is supplied with a grounding conductor and grounding-type attachment plug. To reduce risk of electrical shock, connect only to a properly grounded, grounding-type receptacle.
TO REDUCE THE RISK OF ELECTRIC SHOCK, INSTALL ONLY ON A CIRCUIT PROTECTED BY A GROUND-FAULT CIRCUIT-INTERRUPTER (GFCI).

⚠ NOTE ⚠

This pump has not been investigated for use in swimming pool or marine areas.
This pump has been evaluated for use with water only.

KOSHIN LTD. www.koshinpump.com

TEL.: +81-75-953-2499 FAX.: +81-75-954-6119
12 Kami-Hachinotsubo Kotari, Nagaokakyo City, Kyoto 617-8511 JAPAN

24-05 043031811

AFTER USING PUMP

1. In cold climates, do not allow pump to freeze.
Remove pump from water to prevent damage due to freezing.
2. Completely drain and dry pump of water before storing.

⚠ CAUTION

The pump is used a double mechanical seal.
(See figure)
Consulting the following table assemble it.

Mechanical seal	Motor side (Carbon)	Pump side (Carborundum)
Outside diameter	20.5 mm	20.0 mm
Internal diameter	16.0 mm	15.5 mm

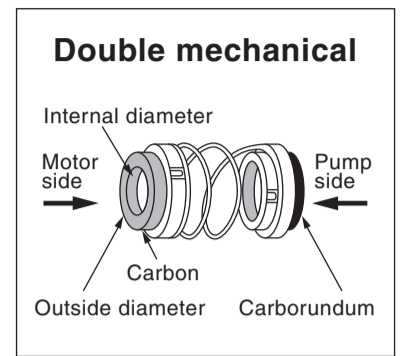

TROUBLESHOOTING GUIDE

PROBLEM	POSSIBLE CAUSE	SOLUTION
No start at all or stops immediately after start	Not properly connected to power circuit	Correct the connection
	The GFCI, leakage circuit breaker is actuated	Check the power circuit
	The impeller is caught by foreign substance	Repair the point of leakage
	Motor is burnt	Repair or replace
	Voltage drop	Raise the voltage to the rating
Failure during operation	The protector is actuated	Remove foreign substance if the impeller is clogged Lower the liquid temperature if it is too high
No pumping or poor performance	Voltage drop	Raise the voltage to the rating
	High delivery head	Lower the head
	Discharge pipe is clogged	Overhauling
	Impeller wear	Replacement
	Clogging of foreign matter in strainer pump	Overhauling

INSTALLATION AND USE

- An acceptable motor-control switch shall be provided at the time of installation.
- Thermally protected

1. This pump works under an automatic surface control system whereby it is automatically switched on and off by a float switch.
2. The pump starts automatically when the water level rises and the float comes up to the ON water level, and stops automatically when the water level falls and the float comes down to the OFF water level.
3. The ON and OFF water levels can be adjusted by loosening the cord band bolt. However, the length of the cord between the cord band and the float switch should be between 50 mm and 150 mm, otherwise the float switch will not operate normally.
4. The float switch should be installed where it does not come into contact with walls or is any other obstructions.
5. The pump should not be installed where water is discharged directly onto the float.

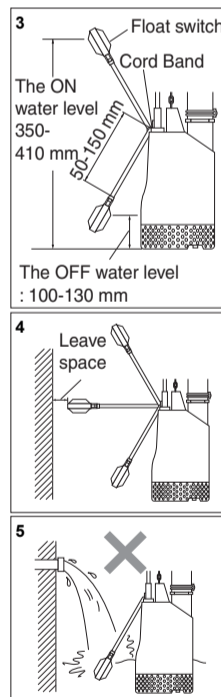

AFTER USING PUMP

1. In cold climates, do not allow pump to freeze.
Remove pump from water to prevent damage due to freezing.
2. Completely drain and dry pump of water before storing.

⚠ CAUTION

1. **Leak Current Breaker**
For home use, attach a leak current breaker, GFCI (offered separately) to ensure safety.
2. **Connect the power source**
Absolutely refrain from connecting this pump to any other power source than 110 V AC or 220 V AC, 50 Hz.
3. **Water to use**
Absolutely refrain from using the pump for any oil, sea water, strong alkaline or strong acidic solution, or any agricultural chemicals.
4. **Do not run dry!**
Idling can cause trouble, to prevent short cycling place pump at deepest position as possible.
5. **Handling of power cord**
 - a. Never lift or move pump by power cord. Only lift by handle or tie rope supplied to handle.
 - b. Select and use proper size extension cord. Do not run extension cord in water.
6. **Using in bath, etc.**
Do not enter the water when pump is being used.

MAINTENANCE AND INSPECTION

1. Periodically check the insulated condition with a megger tester.
To be acceptable, the resistance between the earthing wire and the power cord should be 100 Megohm and higher.
2. The shaft of the water-tight mechanism as the most critical part of the pump is sealed with liquid paraffin. The life changes greatly depending on the operating condition but the quantity should be checked periodically.
Use 230 cc of Crystol No.70 by Exxon Mobil Corporation for the sealing.
The liquid paraffin can be checked easily by removing the hexagon socket head bolt at a lower side of the pump body.

SPECIFICATIONS

MODEL	PX-55011	PX-55022	PX-55022A	PXL-52511	PXL-52522			
Type	BAB	BAA	BAC	BAA	BAB	BAB	BAC	
PUMP	Connection Dia		50 mm (2 in)		25 mm (1 in)			
	Total Head		10 m (32.8 ft)					
	Delivery Volume		260 L/min (68.6 USG/min)		120 L/min (31.7 USG/min)			
MOTOR	Voltage		AC 110 V		AC 220 V		AC 110 V	AC 220 V
	Frequency		50 Hz					
	Rated Current		6.5 A		3.2 A		6.0 A	2.9 A
	Output		400 W					
	Consumption		580 W		620 W		590 W	540 W
	Revolution		2900 rpm					
	Model		Induction Motor					
Power Cord		10 m (32.8 ft)	5 m (16.4 ft)	10 m (32.8 ft)	10 m with Float Switch (32.8 ft)	10 m (32.8 ft)		
Standard Accessories		1 Rope (5 m / 16.4 ft), 1 Hose Band, 1 Hose Nipple			1 Rope (5 m / 16.4 ft), 1 Hose Band, 1 Coupling Packing, 1 Coupling, 1 Hose Nipple			
Net Weight		11.9 kg (26.2 lbs)	11.1 kg (24.5 lbs)	11.6 kg (25.6 lbs)	11.8 kg (26.0 lbs)	12.2 kg (26.9 lbs)	11.8 kg (26.0 lbs)	

*Starting current is three times higher than rated current.

PERFORMANCE CURVE

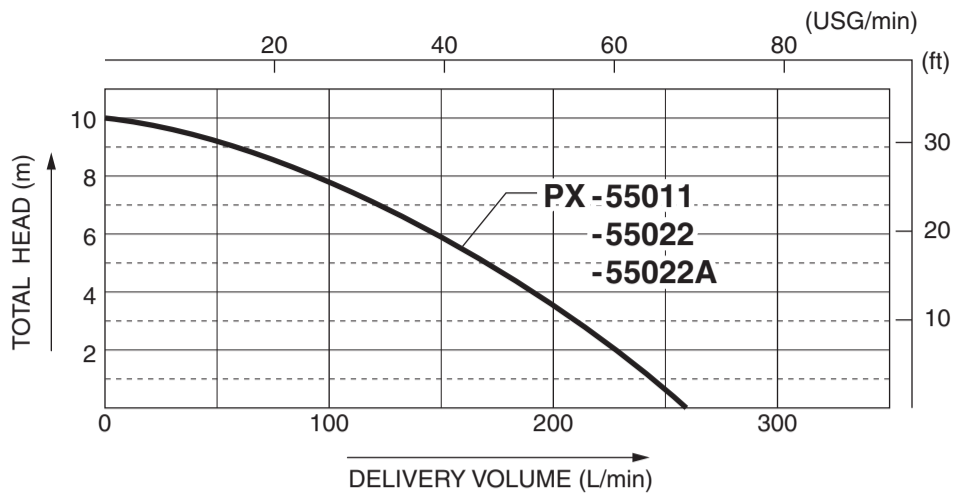

*Performance ratings are guaranteed minimum, not inflated maximum.
 **Starting current is three times higher than rated current.

DIMENSION

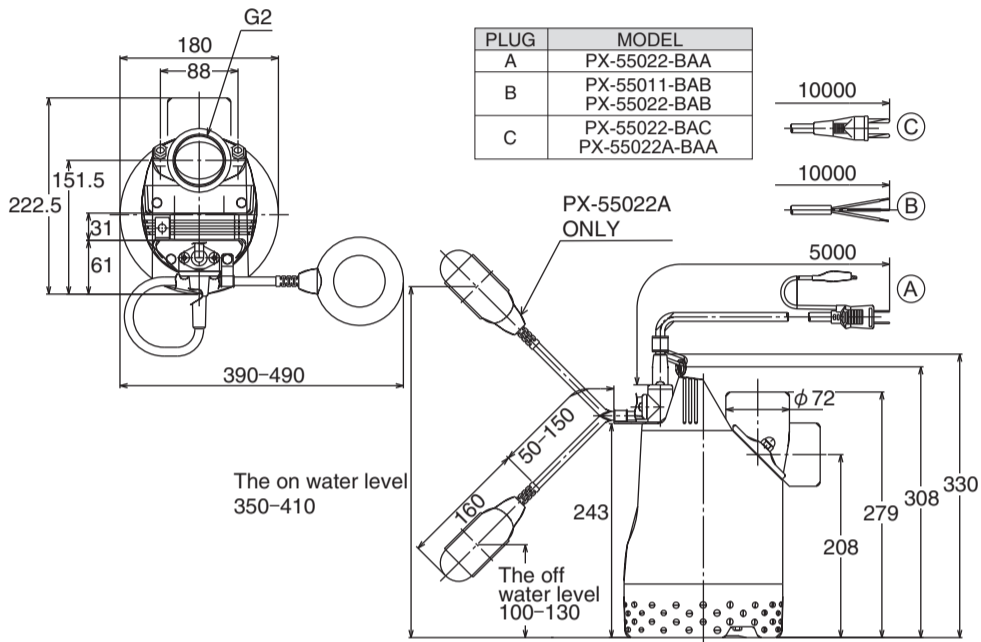

PARTS LIST

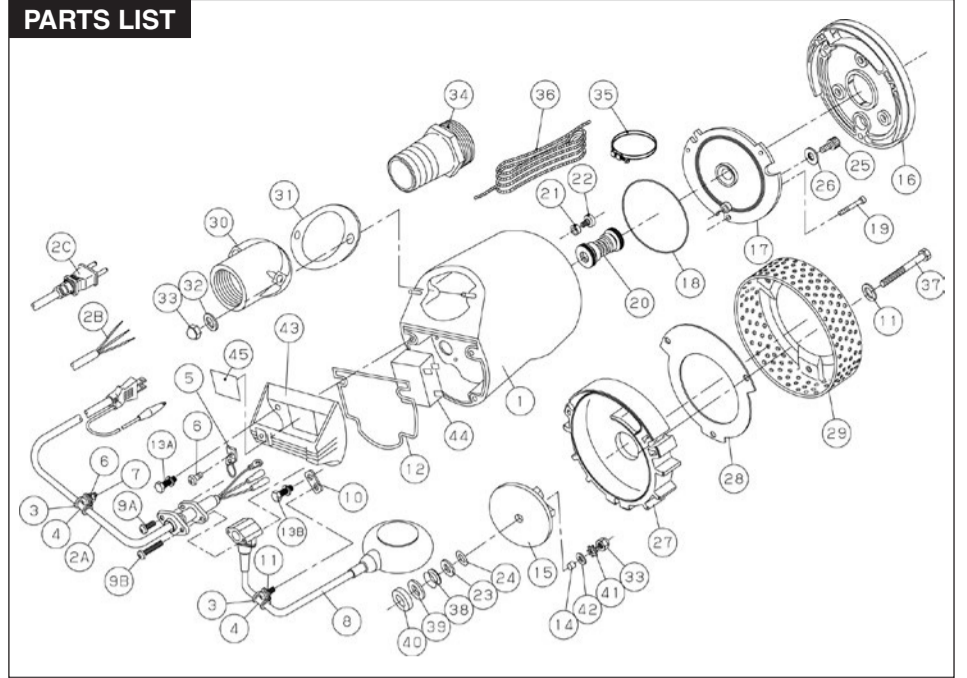

PX-55011-BAB / PX-55022-BAA/BAB/BAC / PX-55022A-BAA

No.	PARTS CODE	PARTS NAME	QTY	No.	PARTS CODE	PARTS NAME	QTY
1	0438123	PX-5011 MOTOR ASSY 110V	1	23	0430300	IMPELLER WASHER	1
	0438120	PX-5022 MOTOR ASSY 220V	1	24	0390025	IMPELLER ADJUSTING WASHER	2
	0438151	PX-5022 CE MOTOR ASSY 220V	1	25	0390037	SOCKET BOLT M10x12	1
2A	0430289	POWER CORD ASSY 5m	1	26	854255010	SEAL WASHER φ10	1
2B	0438102	CE POWER CORD ASSY 10m	1	27	0430274	CASING	1
2C	0438142	EU POWER CORD ASSY 10m	1	28	0430269	SUCTION	1
3	0390031	CORD SUPPORTER	1	29	0430270	STRAINER	1
4	0260018	CORD BAND	1	30	0430305	DELIVERY FLANGE G2	1
5	0438066	CHAIN ASSY	1	31	0430283	DELIVERY PACKING	1
6	703305100	⊕SCREW M5x10	2	32	846005008	WASHER φ8	5
7	827305005	HEXAGON NUT M5	1	33	835305008	HEXAGON CAP NUT M8	3
8	0438155	FLOAT ASSY	1	34	0390213	HOSE NIPPLE φ50	1
9A	703305104	⊕SCREW M5x14	2	35	940019060	HOSE BAND φ60	1
9B	703305110	⊕SCREW(55022A) M5x50	2	36	0398020	PS ROPE 5M	1
10	0390330	SUPPORT PLATE	1	37	735705162	HEXAGON BOLT M8x70	3
11	707805046	⊕SCREW M5x12	1	38	895154014	OIL SEAL VR14A	1
12	0430284	HEAD PACKING	1	39	0430301	THRUST WASHER	1
13A	743605031	HEXAGON BOLT M6x18	4	40	0430299	THRUST PACKING	1
	743605031	HEXAGON BOLT(55022A) M6x18	3	41	845305008	TOOTHED WASHER 8B	1
13B	743605032	HEXAGON BOLT(55022A) M6x20	1	42	846505008	WASHER φ8-1.6	1
14	0430441	IMPELLER FIXING BUSH	1	43	0430268	HANDLE	1
15	0430285	IMPELLER	1	44	0430392	110V CONDENSER(55011) 32μF 260VAC	1
16	0430273	BACK LINER	1		0430393	220V CONDENSER(55022) 8μF 480VAC	1
17	0430271	FRONT COVER	1		0430344	PX-55011-BAB NAME PLATE	1
18	889955125	O-RING G125	1		0430317	PX-55022-BAA NAME PLATE	1
19	734505037	HEXAGON SOCKET BOLT M5x20	3	45	0430336	PX-55022-BAB NAME PLATE	1
20	0390003	MECHANICAL SEAL	1		0430479	PX-55022-BAC NAME PLATE	1
21	0340142	SEAL RING	1		0430558	PX-55022A-BAA NAME PLATE	1
22	0340153	⊕BIND SCREW M6x8	1	46	0390383	PARAFFIN OIL 230CC	1

PERFORMANCE CURVE

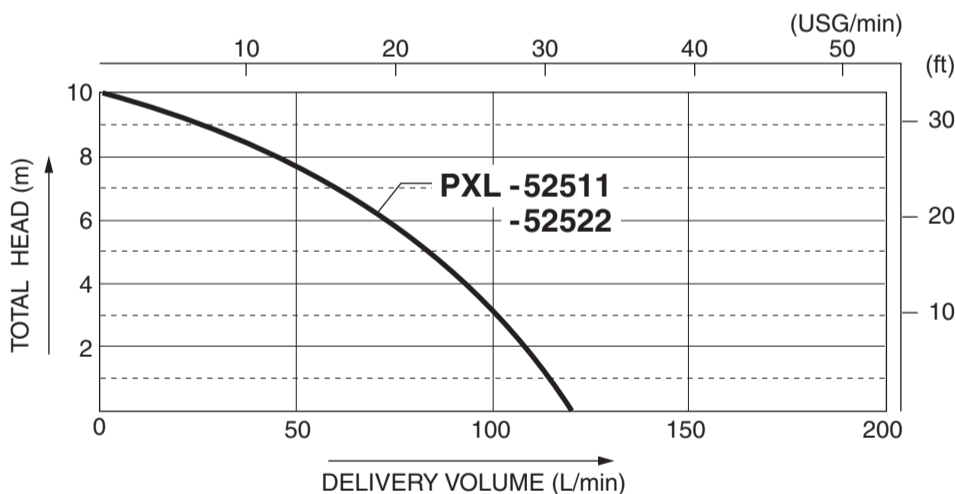

*Performance ratings are guaranteed minimum, not inflated maximum.
 **Starting current is three times higher than rated current.

DIMENSION

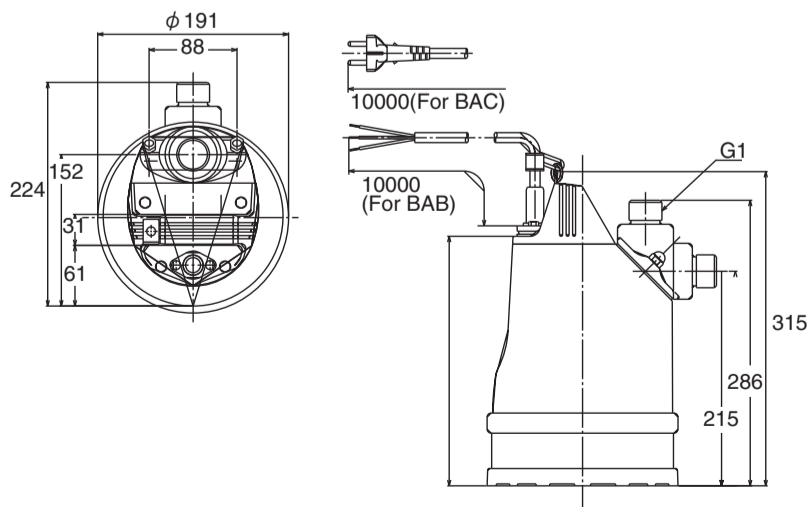

PARTS LIST

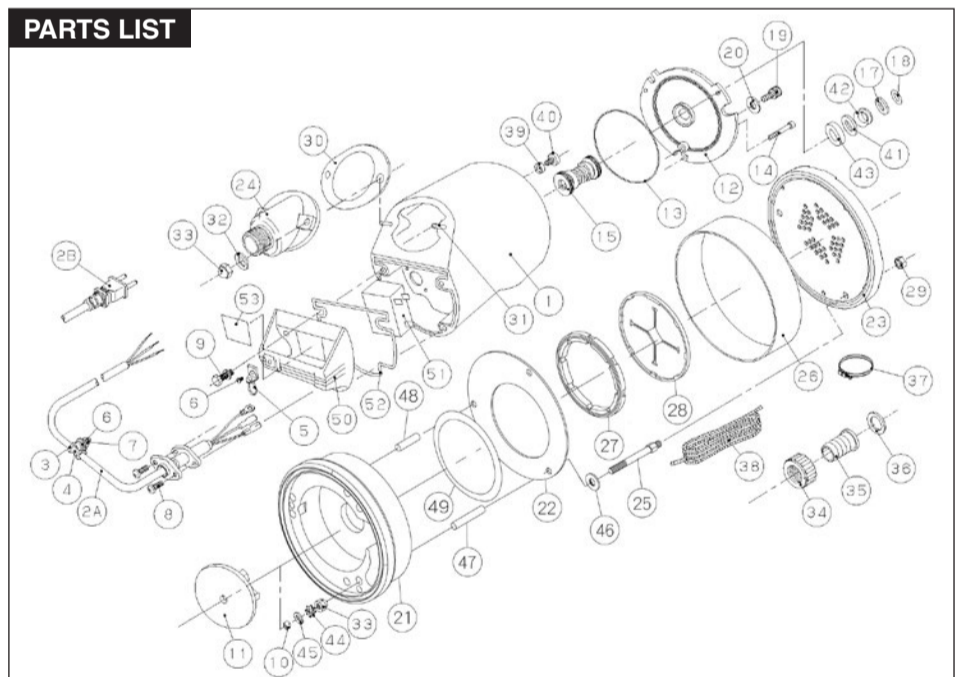

PXL-52511/ PXL-52522

No.	PARTS CODE	PARTS NAME	QTY	No.	PARTS CODE	PARTS NAME	QTY
1	0438123	PX-5011 MOTOR ASSY 110V	1	28	0430331	ONE WAY CHECK VALVE	1
	0438151	PX-5022 CE MOTOR ASSY 220V	1	29	827405008	HEXAGON NUT M8	3
2A	0438102	CE POWER CORD ASSY	1	30	0430283	DELIVERY PACKING	1
2B	0438142	EU POWER CORD ASSY	1	31	0430290	STUD BOLT M8x36x11/21	1
3	0390031	CORD SUPPORTER	1	32	846005008	WASHER φ8	2
4	0260018	CORD BAND	1	33	835305008	HEXAGON CAP NUT M8	3
5	0438066	CHAIN ASSY	1	34	0340781	COUPLING	1
6	703305100	⊕SCREW M5x10	2	35	0340782	HOSE NIPPLE	1
7	827305005	HEXAGON NUT M5	1	36	0340065	COUPLING PACKING	1
8	703305102	⊕SCREW M5x14	2	37	940019032	HOSE BAND φ32	1
9	743605031	HEXAGON BOLT M6x18	4	38	0398020	PS ROPE 5m	1
10	0430441	IMPELLER FIXING BUSH	1	39	0340142	SEAL RING	1
11	0430285	IMPELLER	1	40	0340153	⊕BIND SCREW M6x8	1
12	0430271	FRONT COVER	1	41	0430301	THRUST WASHER	1
13	889955125	O-RING G125	1	42	895154014	OIL SEAL VR14A	1
14	734505037	SOCKET BOLT M5x20	3	43	0430299	THRUST PACKING	1
15	0390003	MECHANICAL SEAL	1	44	845305008	TOOTHED WASHER 8B	1
16	0390383	PARAFFIN OIL 230CC	1	45	846505008	WASHER φ8-1.6	1
17	0430300	IMPELLER WASHER	1	46	854255008	SEAL WASHER φ8	3
18	0390025	IMPELLER ADJUSTING WASHER	2	47	0430361	PX-L LONG PIPE	2
19	0390037	SOCKET BOLT M10x12	1	48	0430362	PX-L SHORT PIPE	1
20	854255010	SEAL WASHER φ10	1	49	0430360	PX-L SUCTION PACKING	1
21	0430334	PX-L CASING	1	50	0430268	HANDLE	1
22	0430329	PX-L SUCTION	1		0430392	110V CONDENSER 32μF/260VAC	1
23	0430241	PX-L STRAINER	1		0430393	220V CONDENSER 8μF/480VAC	1
24	0430350	DELIVERY FLANGE	1	52	0430284	HEAD PACKING	1
25	0430242	STUD BOLT	3		0430379	PXL-52511-BAB NAME PLATE	1
26	0430236	STRAINER STAND	1	53	0430380	PXL-52522-BAB NAME PLATE	1
27	0430239	SEAL RING	1		0430577	PXL-52522-BAC NAME PLATE	1