

KOSHIN

DIESEL ENGINE PUMP

OPERATION MANUAL

SEY-50D, SEY-80D, SEY-100D
STY-50D, STY-80D, STY-100D
KTY-50D, KTY-80D, KTY-100D

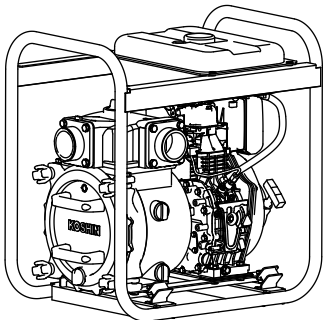
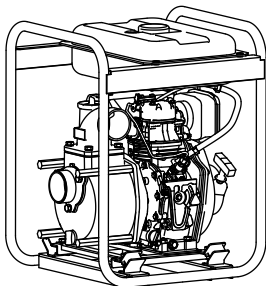
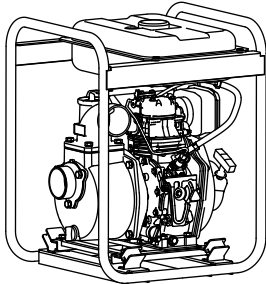

Thank you for purchasing this product.

- Read this manual carefully before using the product.
- Store the manual once you have finished reading it.
- Those who do not understand the content of this operation manual should not operate the product.
- If you lend this product to another person, explain how to use the product and instruct them to read the operation manual carefully.

Please note that the illustrations and content in this operation manual may differ to the actual product due to changes to the specifications.

CONTENTS

INTRODUCTION

NAME OF PARTS.....	2
SAFETY PRECAUTIONS.....	4
OTHER PRECAUTIONS.....	6

PREPARATION

PREPARATIONS FOR STARTING	7
PREPARATIONS FOR PUMP OPERATION	10

HOW TO USE THE PRODUCT

STARTING THE ENGINE AND PUMP	11
STOPPING THE ENGINE AND PUMP	13
AFTER USING THE PRODUCT.....	14
PERIODIC CHECKS AND MAINTENANCE.....	15
LONG-TERM STORAGE	21

INSPECTION AND MAINTENANCE

TROUBLESHOOTING	22
-----------------------	----

OTHER ITEMS

SPECIFICATIONS.....	24
PERFORMANCE CARVE	27
SPAREPARTS	27

NAME OF PARTS

■ Centrifugal pump (Hidels pump), Semi-trash pump

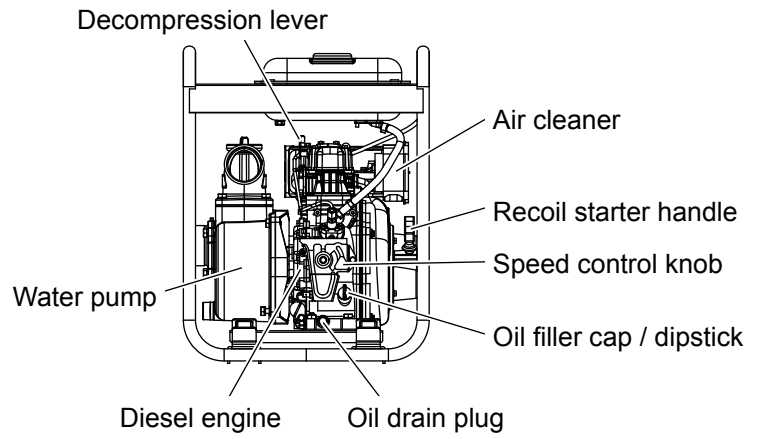
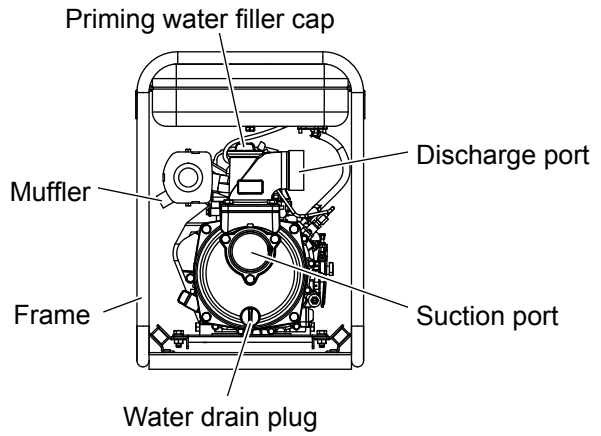
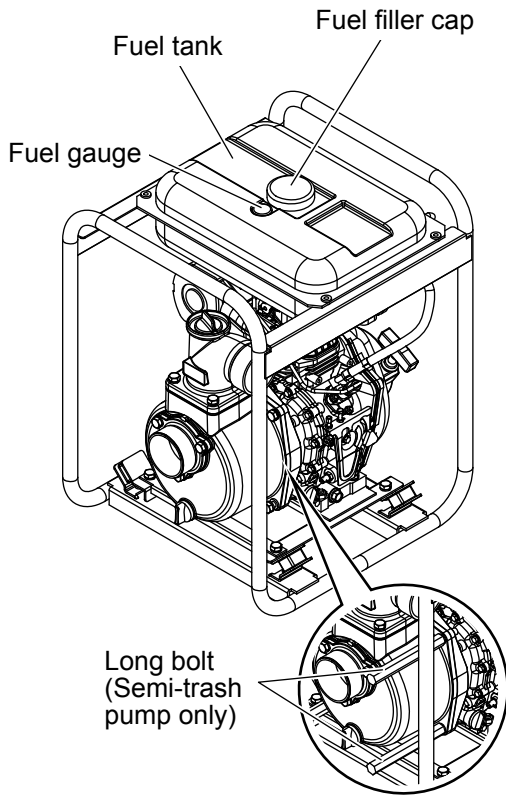

NAME OF PARTS

■ Trash pump (KTY-50D)

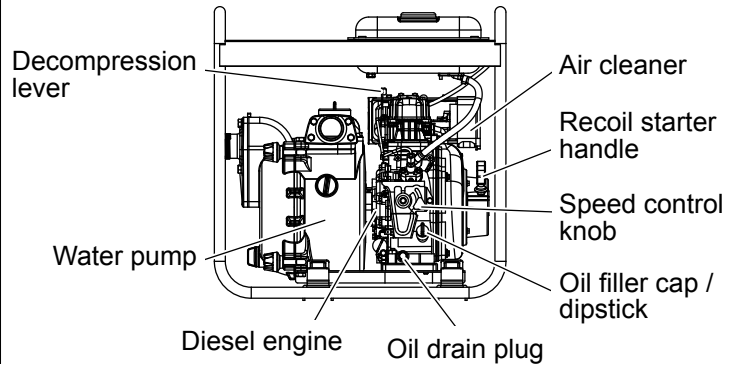
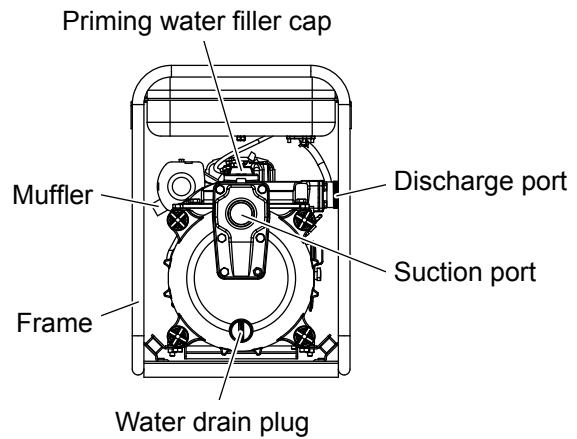
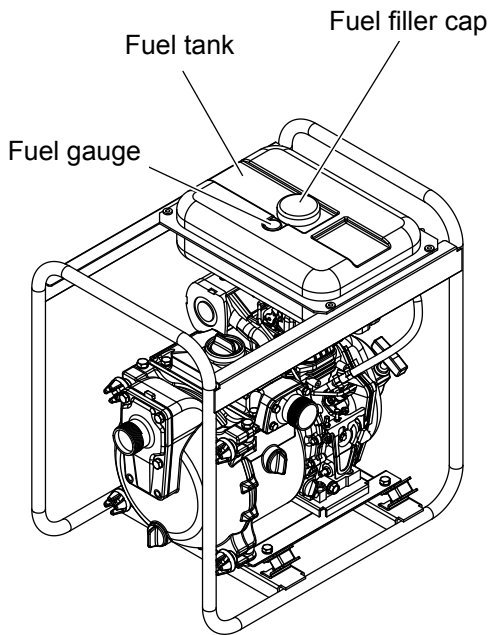

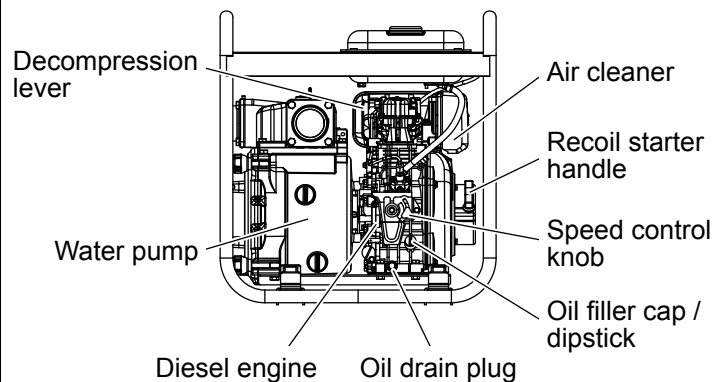
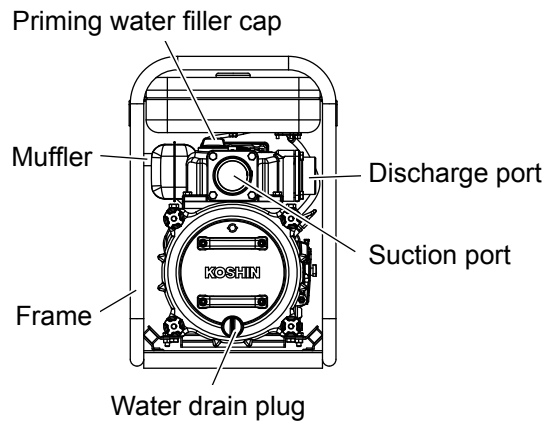
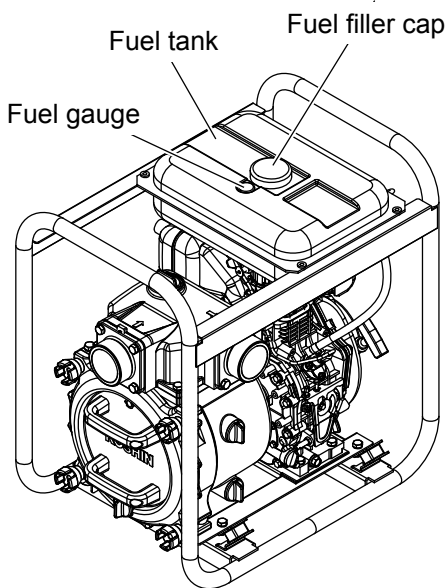

■ Trash pump (KTY-80D, KTY-100D)





SAFETY PRECAUTIONS

Read these safety precautions carefully before using the product. The cautions shown here are for using the product correctly and to prevent hazards and injury to those using the product and other people.

- Injuries and hazards that may occur if the displayed content is ignored and the product is used incorrectly are categorized as "DANGER", "WARNING", and "CAUTION". All categories are important for safety, so always follow them.

 DANGER	Content for which it is considered highly likely a person will die or be seriously injured.
 WARNING	Content for which it is assumed a person may die or be seriously injured.
 CAUTION	Content for which it is assumed a person may be moderately injured and property damage may occur.

- Content that you must follow is described in categories.

 "PROHIBITED" content that you must not do.	 "EXECUTE" content that you must comply with.
---	---

- Other indications: **NOTICE** ...Indicates the correct way to operate the product, and notes on inspection and maintenance.

WARNING

PREVENTING FIRES

Never add fuel to the fuel tank while the engine is running. Wipe away all fuel spills with a clean cloth. Keep gasoline, kerosene, matches, other explosives and flammable away from the product, since the temperature around the exhaust muffler is very high during operation.

- To prevent fire hazards and to provide adequate ventilation, keep the pump at least 1 m (3 ft) away from the building and other equipment during operation.
- Operate the pump on a flat, level, and firm surface. If the pump is tilted, fuel spillage may result.

PREVENTING EXHAUST GAS INHALATION

- Exhaust gas contains poisonous carbon monoxide.
- Never use the pump in poorly ventilated locations such as indoors or inside tunnels. If indoor operation is unavoidable, provide proper ventilation so that people and live stock will not be affected.

PREVENTING BURNS

- Never touch the muffler, muffler cover or engine body while the engine is running or hot.

OTHER SAFETY ITEMS

- As this product is heavy, you may be injured if you drop it on your feet or hurt your back when moving it, so use several people to move it.
- Know how to stop the pump quickly and understand how to deal with all of the controls. Never permit anyone to operate the pump without proper instructions.
- Always wear a helmet and safety shoes (non-skid soles) and proper clothes.
- Do not operate under influence of alcohol.
- Keep children and pets away from the pump when it is in operation.
- Keep away from rotating parts while the pump is running.
- Work according to rules and regulations of work area.

OTHER PRECAUTIONS

While the engine is still new, applications of heavy loads may shorten the life of the engine. During the first 20 hours, follow the break-in procedures.

1. Avoid overloads

During break-in period, avoid applying heavy loads before the engine is stabilized.

2. Change engine oil regularly

About one month or 20 hours after initial starting and every 3 months or 100 hours thereafter, change the engine oil while the engine is still warm.

NOTICE

- Be sure to drain the oil while the engine is warm, otherwise it may be difficult to drain the oil completely.

PREPARATIONS FOR STARTING

Selection and Handling of Fuel Oil

1. Selection of fuel oil

Use the most suitable diesel fuel oil for the engine.

2. Keep dust and water out of the fuel

When filling the fuel tank from drums, make sure no dust or water are mixed in with the fuel since this may lead to serious fuel injection pump and nozzle problems.

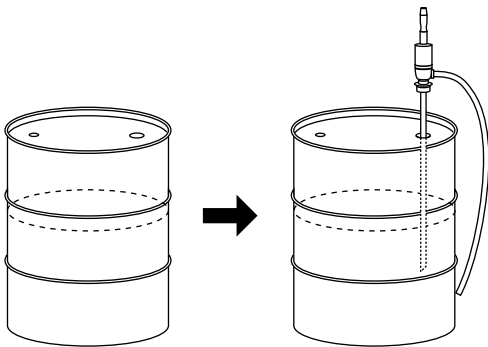

After purchasing fuel: Allow drum to stand 3-4 days

After 3-4 days: Put a suction pipe halfway into the drum (Water and dust accumulate in the lower portion of the drum)

CAUTION

Only use the recommended diesel fuel oil.

Use of non-recommended fuel may cause clogging in the fuel oil strainer, fuel injection pump and fuel injection nozzle. This clogging often causes sudden engine stops just after starting.

The fuel should have a Cetane value of more than 45 in order to prevent difficult starting, misfiring and white exhaust smoke.

Diesel fuel oil substitutes are not recommended; they may be harmful to fuel system components.

The fuel should be free of water and dust, because these can cause trouble in the fuel injection pump and nozzle.

3. Do not overfill

Overfilling is dangerous. With the engine level, do not fill the tank beyond the top of the indicating ring (red) inside the fuel tank filter.

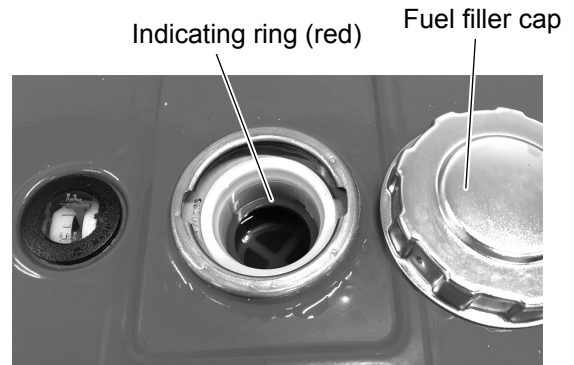

The fuel gauge displays how much fuel is remaining. When the fuel tank is full, the red indication is at "F" and gets closer to "E" as fuel is consumed. When the red indication bar gets to "E", refuel the engine as soon as possible.

Fuel gauge

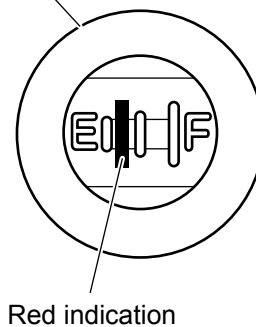

NOTICE

- The display is only a guide. Always check the fuel limit position on the indicating ring (red) inside the fuel tank filter.
- Check the indication when the product is level. If the product is on an angle, you will not get an accurate reading.

PREPARATIONS FOR STARTING

⚠ WARNING

Refuel in a well ventilated area with the engine stopped. Also check that the engine has sufficiently cooled.

Do not smoke or allow flames or sparks in the area where the engine is refueled or where fuel is stored.

Do not overfill the tank and make sure the filler cap is securely closed after refueling.

Be careful not to spill fuel when refueling. If any fuel is spilled, make sure the area is dry before starting the engine.

Selecting and Handling Engine Oil

Use proper engine oil.

If inferior oil is used, or if the engine oil is not changed regularly, the risks of piston seizure, piston ring sticking, accelerated wear of the cylinder liner, bearings and other moving components increases significantly. The pump's life may be seriously shortened. We recommend CD or Higher oil of API grade classification.

Always use oil with the right viscosity for the ambient temperature in which the engine is being operated. Use the chart below when choosing the engine oil.

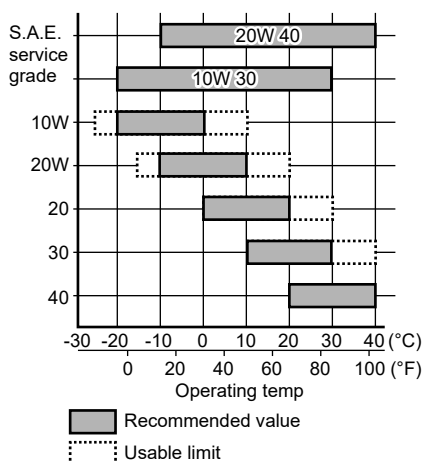

Fill the oil up to the mouth of the filler port with the engine placed on the level.

	SEY-50D / SEY-80D / STY-50D / STY-80D / KTY-50D	SEY-100D / STY-100D / KTY-80D	KTY-100D
Engine oil capacity	0.8 L	1.1 L	1.6 L

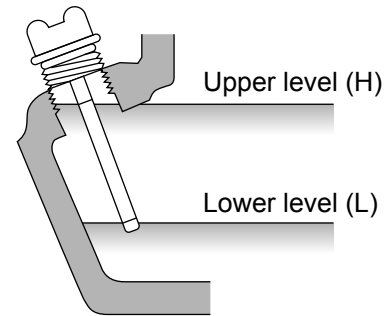

Fill up to the top of the filler port with the engine on the level

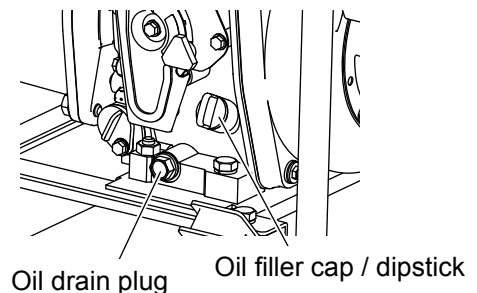

⚠ WARNING

Before checking the oil level, make sure the pump is sitting level.

If it is tilted, you may add either too much or too little oil. Consequently, you may overfill and the engine will consume too much oil and the oil temperature will become dangerously high: or you may not add enough oil, and the engine could seize up. Faults caused by engine seizure are not covered by the warranty.

⚠ CAUTION

When checking the oil, simply dip the dipstick into the oil pan. Do not screw in the dipstick.

Be sure to check the engine on a level surface with the engine stopped.

PREPARATIONS FOR STARTING

Servicing the Air Cleaner

1. Loosen the wing nut, detach the cover of the air cleaner and remove the element.

⚠ CAUTION

Do not wash the air cleaner element with detergent.

Replace the element if output falls or a bad exhaust color is noticed.

Never run the pump without an air cleaner element. Sand or foreign matter is prone to getting inside the engine, which may hasten engine wear and tear.

2. Reattach the cover of the air cleaner and tighten the wing nut.

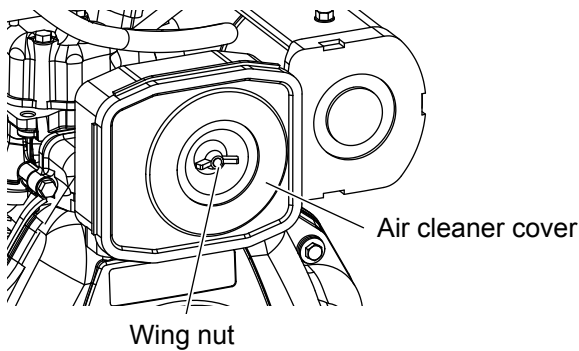

PREPARATIONS FOR PUMP OPERATION

Different accessories are suitable for different models. Please check connection diameter and install correct parts.

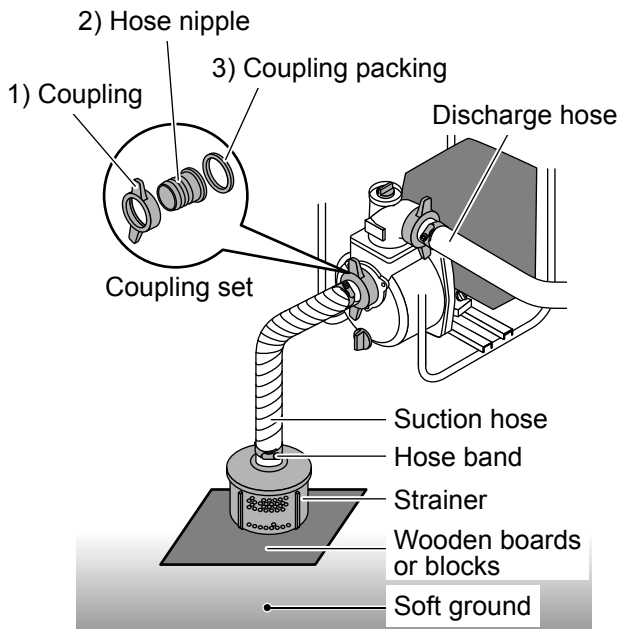

How to Install the Coupling

Please install coupling in order of :

1) -> 2) -> 3).

If you install coupling packing not in above order, air leakage may result, affecting water suction efficiency.

Preparations for Pump Operation

1. **Fix the strainer at the end of the suction side hose and tighten it with the hose band. Then place it in the water.**
Make sure suction hose is connected properly. In case of no self-priming after filling pump with water and engine is started, check suction hose connection carefully again. Most cases of no self-priming are caused by improper hose connection.

NOTICE

- Use suction hose for suction side.
- Do not change pump diameter by altering suction hose.

- Pump failure will occur if the suction strainer is not properly fitted.
The strainer keeps the size of the suspended solids entering the pump to the predetermined size the pump has been designed to handle.
- The strainer should be installed in the position where water accumulates most easily. When installing on soft ground, such as gravel or sand, position wooden boards or blocks, etc. below the strainer to prevent it from sinking into the ground. Alternatively, suspend the hose avoiding the bottom.

2. **Fix the suction side hose to the suction port of the pump and tighten it with a band.**
3. **Fix the discharge port side hose to the pump and tighten it with a band.**
4. **Fix the end of the hose to the place where water is required.**

Ensure no obstacle is at discharge hose side.

Do not block, kink, or obstruct the flow of liquid through the discharge hose.

5. **Fill the water pump with water. (This water is called "priming water".) Remove the priming water filler cap and pour the water with a bucket or cup. Fill up until water is discharged from the discharge port.**

As pump is self-priming type, fullfill water fully from priming port into pump casing before running.

Breakdowns caused by dry running are not covered by the warranty.

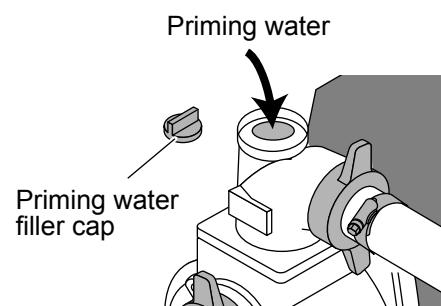

STARTING THE ENGINE AND PUMP

1. Put the engine speed control knob on the "RUN" position. "Run" and "High" are the same position.

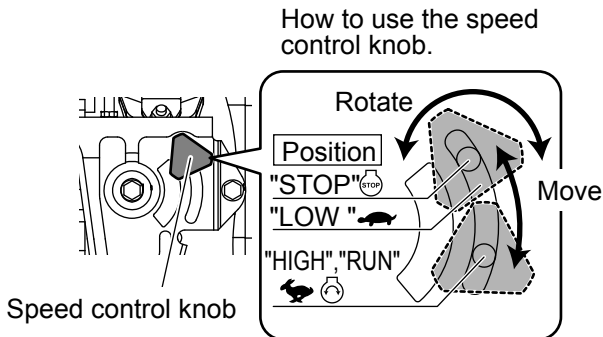

2. Pull out the recoil starter handle to the point where you feel strong resistance, and then slowly return it to the initial position.

If you do not return it slowly, the handle will move around violently and may hit other parts damaging them.

Recoil starter handle

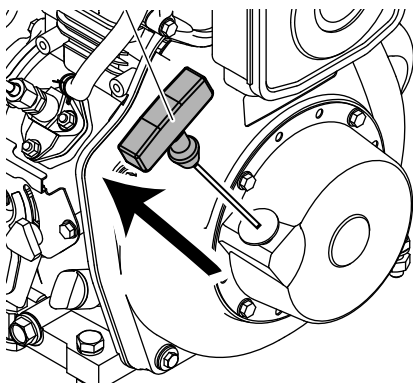

3. Push down the decompression lever.

It will return automatically when the recoil starter (rope) is pulled.

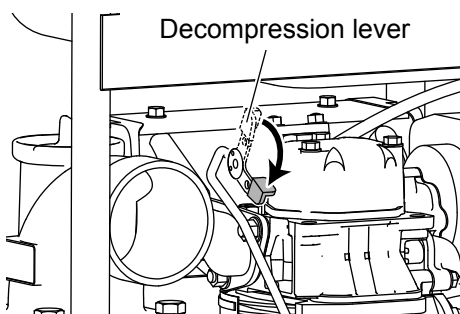

NOTICE

- Make sure to lower the decompression lever and then pull the recoil starter handle. Not doing so may cause engine failure. Engine faults caused by not using the decompression lever are not covered by the warranty.

4. Pull out the recoil starting handle briskly with both hands.

Once the engine starts, slowly return the handle to its initial position. If you do not return it slowly, the handle will move around violently and may hit other parts damaging them.

Recoil starter handle

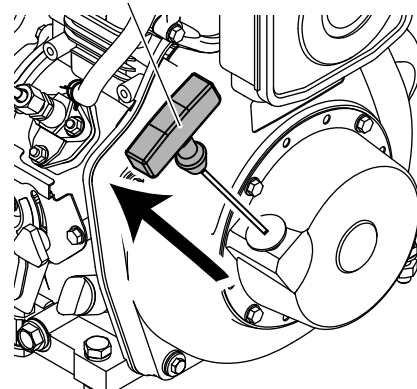

NOTICE

- Do not pull the handle after starting the engine. Doing so may cause engine failure.

5. Until engine rotations stabilize, put the speed control knob into the "LOW" position (warming up).

NOTICE

- Note that if the knob position goes too far, the engine will stop.

STARTING THE ENGINE AND PUMP

6. **Wait for a while (for 2–3 minutes) until water is discharged. If no water is discharged, perform the following actions.**

- Remove the cap and add priming water.

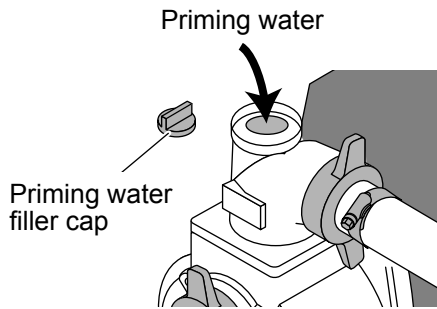

- Confirm that the strainer on the suction port side is under the water level.

NOTICE

- If the water pump is operated for a long time without discharging water, the inside of the pump may be damaged. Breakdowns caused by dry running are not covered by the warranty.

7. **When water is discharged, set the engine speed knob according to the discharging-Volume.**

Adjust the engine speed using the engine speed control knob.

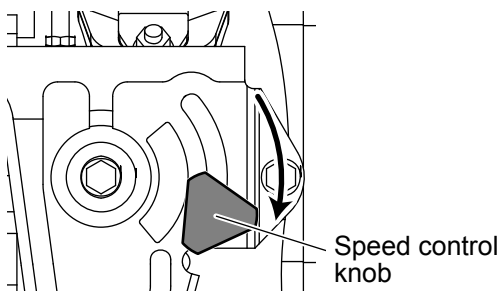

Checks during Operation

⚠ WARNING

Never refuel the engine while it is running or when it is hot even if the engine is stopped.

NOTICE

- Beware of water hammering
Do not allow any vehicle to run over the discharge hose. Do not close the discharge valve abruptly because water-hammer may occur. This may result in heavy damage to the pump.

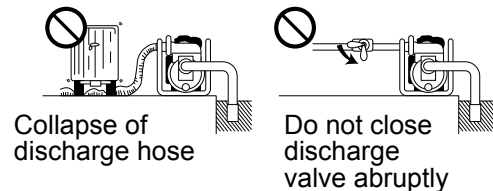

- Any abnormal sound or vibration?
- Is the engine misfiring or running rough?
- What about the color of the exhaust gas? (Is it black or too white?)
- Is there a fuel leak?
- Has the product moved due to engine vibrations?

If you notice any of the above, stop the engine and consult with the nearest dealer.

Operating Condition

- Temperature: 5 to 40 °C
- Humidity: 85 % or below
- Height: 1000 m or below

STOPPING THE ENGINE AND PUMP

1. Cooling-down before stopping the engine, turn the engine speed knob to the "SLOW" position and turn the engine for about three (3) minutes.

CAUTION

Reduce the load slowly when stopping the engine. Do not stop the engine suddenly since this may cause the temperature to rise abnormally.

2. Turn the engine speed control knob to the "STOP" position.

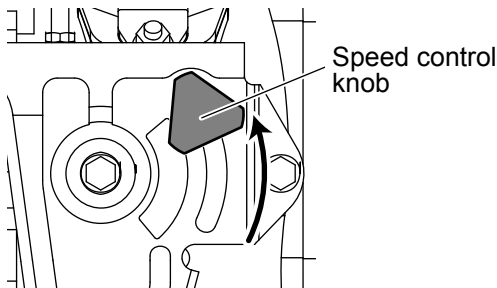

WARNING

If the engine continues to run even if the speed control knob is in the "Stop" position, stop the engine by loosening the nut on the pump's high pressure fuel pipe. Make sure to ask your dealer to tighten the nut after that. As this part is under high pressure, it is dangerous if the nut is not tightened correctly.

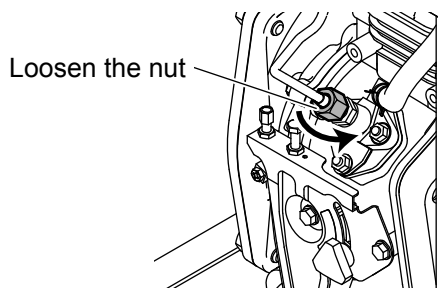

3. Slowly pull out the recoil handle until pressure is felt (that is, to the point in the compression stroke where the intake and exhaust valves are closed), and leave the handle in this position.

This prevents rust from forming while the engine is not in use.

AFTER USING THE PRODUCT

1. Drain water after use

- After use, remove the drain plug at the bottom and pour water from the suction / discharge ports so that the remaining sand is forced out of the pump. If the pump is used to transfer muddy water over a long period of time, a large volume of sand will be piled up in the pump casing, making it difficult to remove the front cover. Therefore, clean the inside the pump periodically.

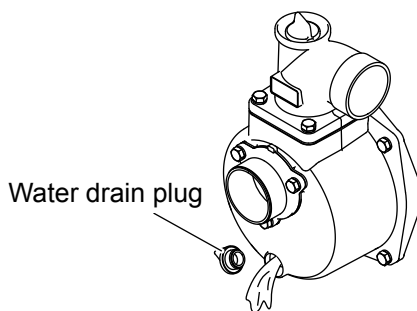

NOTICE

- Water inside may freeze at below 0 °C in winter and may damage pump. Frozen cracks of pump are not covered by the warranty.
2. **Fill the fuel up to indicating ring (red) of the fuel tank filter.**
 3. **Confirm that the bolts and nuts are tightened properly, and if not, tighten them.**
 4. **Wipe away any dust and dirt on the outside of the engine with a clean cloth.**

PERIODIC CHECKS AND MAINTENANCE

To keep the engine in good condition and durable for a long time, periodic checks and maintenance are very important.

The chart below indicates what checks to make and when to make them.

The mark (●) indicates that special tools and skills are required. Consult with the dealer.

WARNING

Shut off the engine before performing any maintenance. If the engine must be run, make sure the area is well ventilated. The exhaust contains poisonous carbon monoxide gas.

CAUTION

After the pump has been used clean the pump immediately with a cloth to prevent corrosion or to remove sediment.

Always use the specified parts. The use of replacement parts which are not of equivalent quality may damage the product.

NOTICE

- Service more frequently when using the pump in dusty areas.
- These items should be serviced by an authorized dealer, unless you have the proper tools and are mechanically proficient.

Maintenance schedule

○:Check ◇:Replace ●:Contact your authorized dealer for these maintenance services.

System	Check item	Daily	Periodic maintenance interval						
			Every 50 hours	Every 200 hours	Every 400 hours	Every 1000 hours	Every 1500 hours	Every 2000 hours	
Air intake	Clean or replace air cleaner element - May need more frequent service in dusty conditions			○ 100 hours	◇ 500 hours				
Cylinder head	Adjust intake / exhaust valve clearance		○ 1st time		●				
	Check compression					●			
Fuel injector	Inspect, clean and test fuel injection nozzle						●		

PERIODIC CHECKS AND MAINTENANCE

○:Check ◇:Replace ●:Contact your authorized dealer for these maintenance services.

System	Check item	Daily	Periodic maintenance interval					
			Every 50 hours	Every 200 hours	Every 400 hours	Every 1000 hours	Every 1500 hours	Every 2000 hours
Engine oil	Check engine oil level and add engine oil as necessary	○ Before operation						
	Drain and refill engine oil			◇ 2nd and after				
	Clean engine oil filter - Replace if damaged May need more frequent service in dusty conditions		◇ 1st time		◇ 2nd and after			
	Check for engine oil leakage	○ Before and after operation						
Fuel	Check fuel tank level and add fuel as necessary	○ Before operation						
	Drain and clean fuel tank			○				
	Clean inlet fuel screen		○					
	Replace fuel filter			○	◇			
	Check for fuel leakage	○ Before and after operation						
Hoses	Replace fuel system hose(s)						● Or every 2 years whichever comes first	
	Clean pump casing and check impeller and valve				●			

PERIODIC CHECKS AND MAINTENANCE

How To Change the Engine Oil

Remove the oil filler cap and drain plug and drain the old oil while the engine is still warm. The plug is located on the bottom of cylinder block.

Tighten the drain plug and refill with the recommended oil. (See the section under "Preparations for starting".)

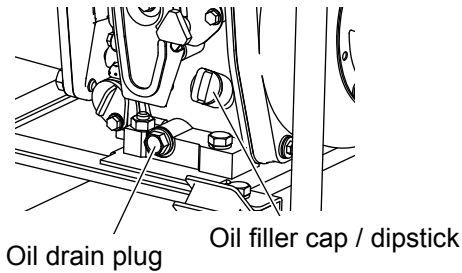

Cleaning Oil Filter

Loosen the fixing bolt and then pull out the oil filter.

Cleaning time	Every 6 months or 400 hours
---------------	-----------------------------

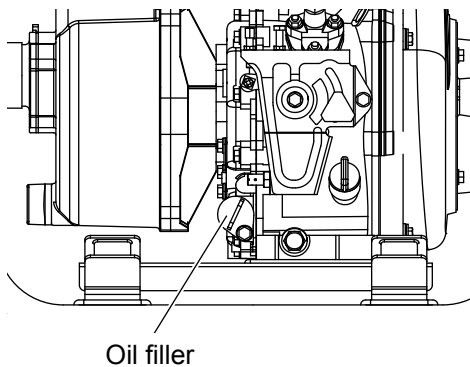

Change the Air Cleaner Element

Do not wash the air cleaner element with detergent because this is wet type (L48N). Clean the filter every 100 hours (L70N / 100N)

Change	Every 6 months or 500 hours (or earlier if dirty)
--------	--

See the section for changing the air cleaner element under "Preparations for starting".



CAUTION

Never run the engine without the element or with a defective element.

NOTICE

- A clogged element hinders the flow of air to the combustion chamber, reducing engine output, increasing lube oil and fuel oil consumption and making starting difficult. Make sure you replace the element regularly.

PERIODIC CHECKS AND MAINTENANCE

Drain the Fuel Tank and Replace Fuel Filter

⚠ DANGER

Always wipe up all spills immediately.

Diesel fuel is flammable and explosive under certain conditions. Store any containers containing fuel in a well-ventilated area, away from any combustibles or sources of ignition. Wipe up all spills immediately and never use a shop rag to catch spilled fuel.

1. Position an approved container under the fuel tank to collect the fuel.
2. Remove the fuel cap (1).
3. Remove the fuel tank drain plug (8) and gasket (9) to drain the fuel. Inspect the gasket and replace if damaged.

NOTICE

- Always be environmentally responsible.
 - Follow the guidelines of the EPA or other governmental agencies for the proper disposal of hazardous materials such as engine oil, diesel fuel and engine coolant. Consult the local authorities or reclamation facility.
4. Remove clamps (2) and disconnect fuel supply (3) and return lines (4).
 5. Remove the fuel tank mounting pins and remove the fuel tank from the frame.
 6. Remove the three fuel filter nuts (5) and pull the fuel filter (6) out through bottom of the tank.
 7. Install a new filter into the tank using a new O-ring (7).
 8. Reinstall the three fuel filter nuts and tighten securely.
 9. Reinstall the drain plug and gasket.
 10. Reinstall the fuel tank into the frame and secure with mounting pins.

11. Reconnect the fuel supply and return lines to the tank with clamps.
12. Fill the fuel tank with fuel and inspect for leaks. Repair or replace components as necessary.

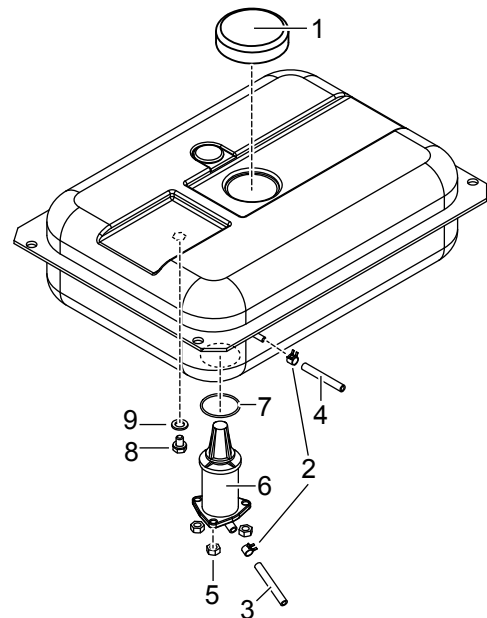

PERIODIC CHECKS AND MAINTENANCE

Cleaning the Inside of the Pump Casing

Remove debris from impeller.
(Do not remove the impeller unless replacing parts.)

- Centrifugal pump (Hidels pump)
- Semi-trash pump

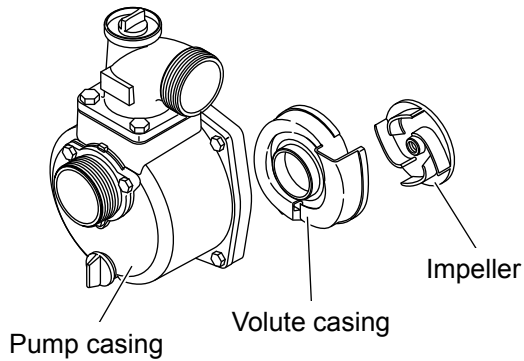

Trash pump

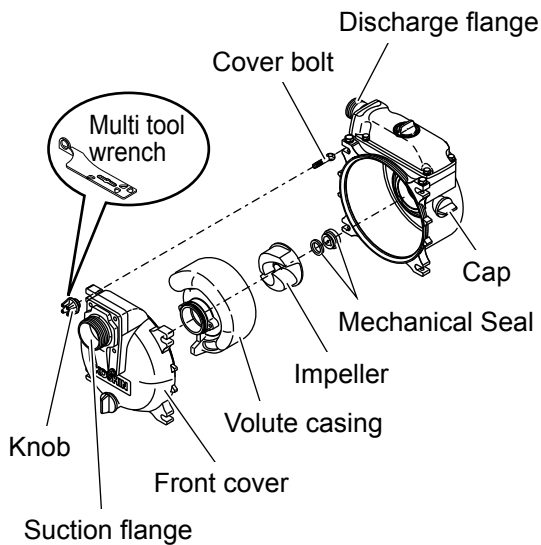

Check hose at suction side

Check suction hose. In case of no suction or small discharge, the cause is usually due to air leakage at suction side. In such case:

1. Remove suction hose.

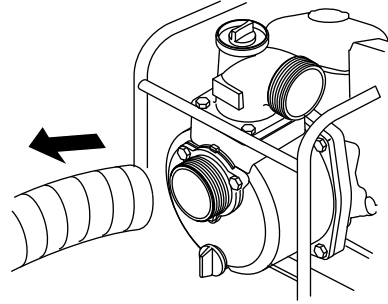

2. Start engine with water inside the pump.

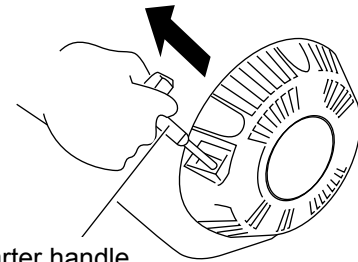

Recoil starter handle

3. Press the palm of your hand to cover the suction hole and wait 30 seconds.

If you feel suction on your palm, the pump is working fine but hose connection needs correction.

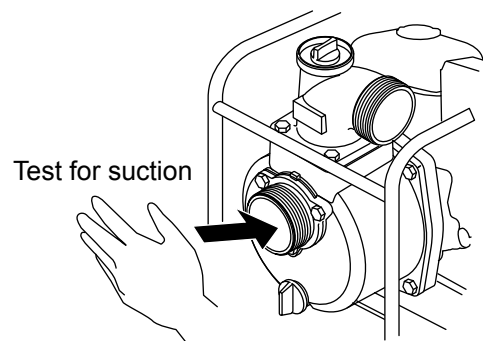

PERIODIC CHECKS AND MAINTENANCE

4. Please check if rubber / gasket packing is installed and if there is any hole and crack in suction hose.

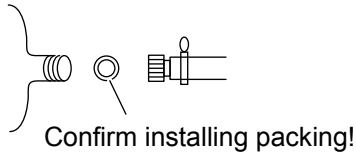
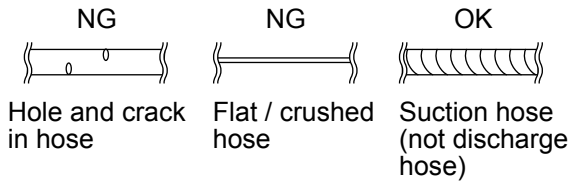

Replacing the Trash pump impeller

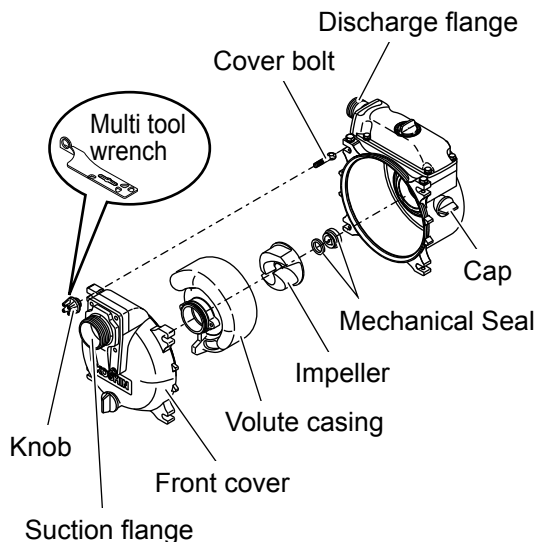

1. Turn the knob counterclock-wise and remove the knob.
2. Pull the front cover towards you, and then both front cover and volute casing can be removed.
3. Remove the peripheral cap before taking impeller out. The impeller can be detached by giving it a shock with a rod or the like.

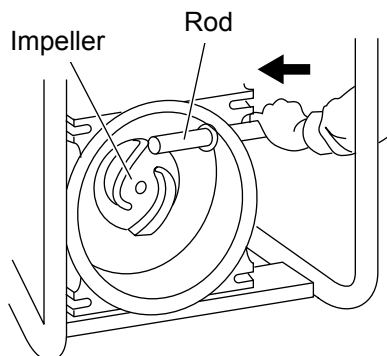

NOTICE

- Please do not hammer an impeller directly when you want to take it out from the machine. It might damage the impeller. Instead, take out the cap first and then insert something like a stick which is thin enough to get through the hole and hammer the stick at the other end.

The impeller can be removed out easily without damaging it.

4. There is one mechanical seal on the impeller and one on the pump unit. When necessary, pull them out to remove them. *The mechanical seals are a two-piece set so make sure to store them as a set.

NOTICE

- When assembling the parts, do not forget to place the adjusting washer, O-ring, etc., in the right positions. Also, correctly install the front cover and evenly tighten the right and left knobs. Note that if the product is not assembled properly, water may leak or pump performance may be affected.

Leak between the pump casing and the engine

A leak between the pump casing and the engine is usually due to a damaged mechanical seal. Refer to a dealer.

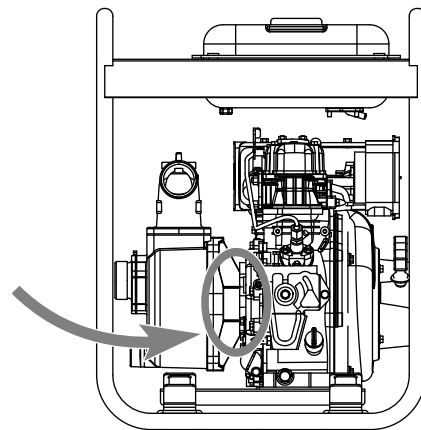

LONG-TERM STORAGE

When storing the pump for long periods, make the following preparations.

1. Fill the pump with clean water and run the engine for about 2 minutes at low speed.
2. Stop the engine. Drain the engine oil while the engine is still warm and fill with new oil.

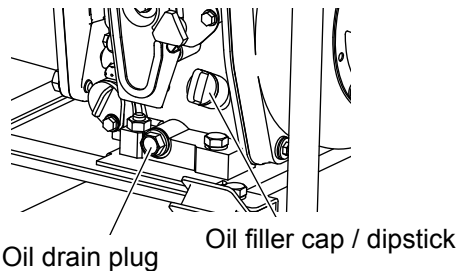

3. Push the decompression lever down (non-compression position) and hold it while you pull the recoil starter 2 or 3 times. (Do not start the engine.)

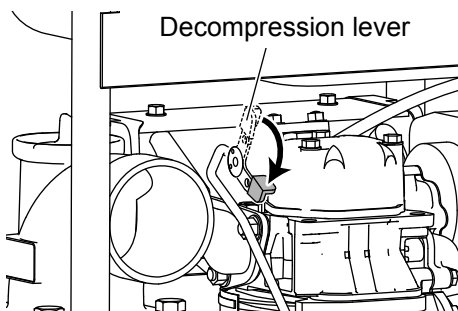

4. Pull the decompression lever up. Pull the recoil starter slowly. Stop when it feels tight. (This closes the intake and exhaust valves in compression position and prevent from rusting).

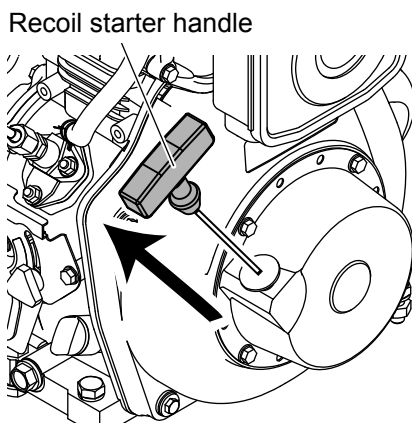

5. Wipe the oil and dirt from the engine and store in a dried place.
6. Remove the drain plug on pump and drain water from pump fully.

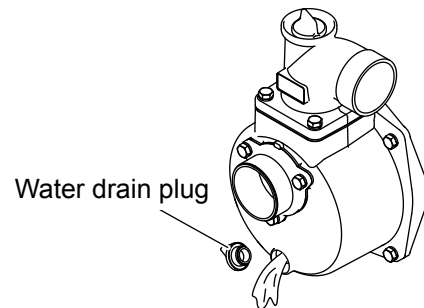

7. Always keep the outside of the water pump clean.

Storage Condition

- Temperature: -20 to 60 °C
- Humidity: 85 % or below
- Location: Outdoors

TROUBLESHOOTING

SYMPTOM	POSSIBLE CAUSE(S)	CORRECTIVE ACTION
Cannot pull or hard to pull recoil starter handle	Old fuel	Replace fuel. If there is no improvement, repair engine
	Rusting inside engine	Repair
	Burn out of engine	Repair
	Blocked impeller	Dismantle & clean the impeller
	Debris at impeller	Dismantle & clean the impeller
	The decompression lever has not been lowered	Push down the decompression lever.
Low discharge volume	Air leakage from suction side	Check hose at suction side
	Low output from engine	Check and repair engine
	Damage of mechanical seal	Replace mechanical seal (Repair)
	The total head (particularly the suction head) is too high	Reduce the total head within the specification.
	Thin or too long or kinks of hose	Thicken or shorten or straight.
	Water leaking from discharge hose or pipe	Check and stop leakage of water
	Debris at impeller	Dismantle & clean the impeller
	Worn or broken impeller	Replace the impeller (Repair)
Suspended solid percentage is too high	Check the specifications and reduce the ratio	
Pump does not prime water	Air leaking in from suction side	Check hose and connections at suction side
	Insufficient priming water inside pump casing	Fill pump with water for priming
	Drain plug is not tightened	Tighten drain plug firmly.

TROUBLESHOOTING

SYMPTOM	POSSIBLE CAUSE(S)	CORRECTIVE ACTION
Pump does not prime water	Engine speed / rpm is too low	Repair
	Damage to mechanical seal	Replace mechanical seal (Repair)
	Wrong suction hose used	Use suction hose correctly
	The atmospheric or water temperature is too hot	Use the product with water that is 40 °C (104 °F) or lower
	Clogged strainer	Clean strainer
	Engine rpm too low	Put speed control knob on "HIGH" position
Engine does not start	Injection nozzle is choked / blocked	Repair
	Air cleaner dirty	Clean air cleaner.
	Incorrect engine oil level	Repair the engine if it seizes
	The fuel pump is blocked	Repair or replace it
	No diesel fuel	Refuel fuel system
	Speed control knob is not in "RUN" position	Put it on "RUN" position
	Check the position of the decompression lever (low position)	Make sure to lower the decompression lever and then pull the recoil starter handle
	Recoil starter is pulled slowly	Pull it quickly and firmly
	Diesel fuel does not reach fuel injection pump or nozzle	Check the injection pump or nozzle
	Abnormal sound from fuel injection nozzle	Check the injection nozzle
	After checking above points, still engine does not start	Possibility of damage, inner parts of engine (Repair)
Oil leakage from muffler or air cleaner	Tipping of engine	Clean engine (air cleaner, injection nozzle, muffler and etc.)

SPECIFICATIONS

Product		Diesel engine pump			
Model		SEY-50D	SEY-80D	SEY-100D	
Category		Self-priming, Centrifugal pump (Hidels pump)			
Applicable liquids	Consistency		Clear water		
	Suspended solid percentage		-		
	Max. solids size		5 mm (0.19 ")	7 mm (0.27 ")	9 mm (0.35 ")
	Temperature		5 °C – 40 °C (41 °F – 104 °F)		
Set	Fuel tank capacity	Tank size	13 L (3.43 USG)		
		Usage level	11 L (2.90 USG)		
	Accessories		1 Strainer, 2 Hose coupling sets, 3 Hose bands, 1 Engine tool set		
	Net weight		44.7 kg (98.5 lbs)	46.7 kg (103.0 lbs)	67.0 kg (144.7 lbs)
	Gross weight		49.3 kg (108.7 lbs)	51.7 kg (114.0 lbs)	75.8 kg (167.1 lbs)
	Product dimensions L x W x H (mm)		515 x 480 x 665		635 x 480 x 755
	Pump	Connection dia		50 mm (2 ")	80 mm (3 ")
Connection thread		BSP			
Total head		30 m (98 ft)	26 m (85 ft)	28 m (91 ft)	
Discharge volume		630 L/min (166 USG/min)	880 L/min (232 USG/min)	1250 L/min (330 USG/min)	
Max. suction head		8 m			
Engine	Type		Forced air-cooled 4-stroke diesel engine		
	Model		YANMAR L48N6		YANMAR L70N6
	Exhaust volume		219 cc		320 cc
	Rated output		3.1 kW (4.2 PS) / 3600 rpm		4.4 kW (6.0 PS) / 3600 rpm
	Max. output		3.5 kW (4.7 PS) / 3600 rpm		4.9 kW (6.7 PS) / 3600 rpm
	Fuel		Diesel fuel		
	Continuous operating time *1		Approx. 10.6 hrs		Approx. 7.7 hrs
	Engine oil		API grade CD or above		
	Engine oil capacity		0.8 L		1.1 L
	Starting method		Recoil starter		

*1: Figure when fuel is filled up to fuel limit position.

SPECIFICATIONS

Product		Diesel engine pump			
Model		STY-50D	STY-80D	STY-100D	
Category		Self-priming, Semi-trash pump			
Applicable liquids	Consistency		Sandy and muddy water (suspended solids) *1		
	Suspended solid percentage		10 % *2		
	Max. solids size		8 mm (0.31 ")	9 mm (0.35 ")	9 mm (0.35 ")
	Temperature		5 °C – 40 °C (41 °F – 104 °F)		
Set	Fuel tank capacity	Tank size	13 L (3.43 USG)		
		Usage level	11 L (2.90 USG)		
	Accessories		1 Strainer, 2 Hose coupling sets, 3 Hose bands, 1 Engine tool set 1 Wrench		
	Net weight		45.1 kg (99.4 lbs)	47.7 kg (105.2 lbs)	68.6 kg (151.2 lbs)
	Gross weight		50.3 kg (110.9 lbs)	53.3 kg (117.5 lbs)	77.5 kg (170.9 lbs)
	Product dimensions L x W x H (mm)		515 x 480 x 665		635 x 480 x 755
	Pump	Connection dia		50 mm (2 ")	80 mm (3 ")
Connection thread		BSP			
Total head		30 m (98 ft)	26 m (85 ft)	28 m (91 ft)	
Discharge volume		630 L/min (166 USG/min)	880 L/min (232 USG/min)	1250 L/min (330 USG/min)	
Max. suction head		8 m			
Engine	Type		Forced air-cooled 4-stroke diesel engine		
	Model		YANMAR L48N6		YANMAR L70N6
	Exhaust volume		219 cc		320 cc
	Rated output		3.1 kW (4.2 PS) / 3600 rpm		4.4 kW (6.0 PS) / 3600 rpm
	Max. output		3.5 kW (4.7 PS) / 3600 rpm		4.9 kW (6.7 PS) / 600 rpm
	Fuel		Diesel fuel		
	Continuous operating time *3		Approx. 10.6 hrs		Approx. 7.7 hrs
	Engine oil		API grade CD or above		
	Engine oil capacity		0.8 L		1.1 L
	Starting method		Recoil starter		

*1: Sandy and muddy water (suspended solids) are defined as debris "floating" within the water.

*2: If the suspended solid percentage is higher, premature wear and failure will occur. To properly pump water with any debris, any solids must be in a suspension.

*3: Figure when fuel is filled up to fuel limit position.

SPECIFICATIONS

Product		Diesel engine pump			
Model		KTY-50D	KTY-80D	KTY-100D	
Category		Self-priming, Trash pump			
Applicable liquids	Consistency		Sandy and muddy water (suspended solids) *1		
	Suspended solid percentage		25 % *2		
	Max. solids size		20 mm (0.78 ")	27 mm (1.06 ")	27 mm (1.06 ")
	Temperature		5 °C – 40 °C (41 °F – 104 °F)		
Set	Fuel tank capacity	Tank size	13 L (3.43 USG)		
		Usage level	11 L (2.90 USG)		
	Accessories		1 Strainer, 2 Hose coupling sets, 3 Hose bands, 1 Engine tool set		
			1 Multi tool wrench		
	Net weight		63.4 kg (139.8 lbs)	82.4 kg (181.7 lbs)	108.5 kg (239.2 lbs)
	Gross weight		70.1 kg (154.5 lbs)	90.3 kg (199.1 lbs)	118.4 kg (261.0 lbs)
	Product dimensions L x W x H (mm)		675 x 480 x 680	690 x 490 x 735	725 x 515 x 745
Pump	Connection dia		50 mm (2 ")	80 mm (3 ")	100 mm (4 ")
	Connection thread		BSP		
	Total head		24 m (79 ft)	23 m (75 ft)	27 m (89 ft)
	Discharge volume		650 L/min (172 USG/min)	1250 L/min (330 USG/min)	1600 L/min (422 USG/min)
	Max. suction head		8 m		
Engine	Type		Forced air-cooled 4-stroke diesel engine		
	Model		YANMAR L48N6	YANMAR L70N6	YANMAR L100N6
	Exhaust volume		219 cc	320 cc	435 cc
	Rated output		3.1 kW (4.2 PS) / 3600 rpm	4.4 kW (6.0 PS) / 3600 rpm	6.6 kW (9.0 PS) / 3600 rpm
	Max. output		3.5 kW (4.7 PS) / 3600 rpm	4.9 kW (6.7 PS) / 3600 rpm	7.4 kW (10.0 PS) / 3600 rpm
	Fuel		Diesel fuel		
	Continuous operating time *3		Approx. 10.0 hrs	Approx. 7.5 hrs	Approx. 5.0 hrs
	Engine oil		API grade CD or above		
	Engine oil capacity		0.8 L	1.1 L	1.6 L
	Starting method		Recoil starter		

*1: Sandy and muddy water (suspended solids) are defined as debris "floating" within the water.

*2: If the suspended solid percentage is higher, premature wear and failure will occur. To properly pump water with any debris, any solids must be in a suspension.

*3: Figure when fuel is filled up to fuel limit position.

PERFORMANCE CARVE

■ Centrifugal pump (Hidels pump), Semi-trash pump (SEY / STY series)

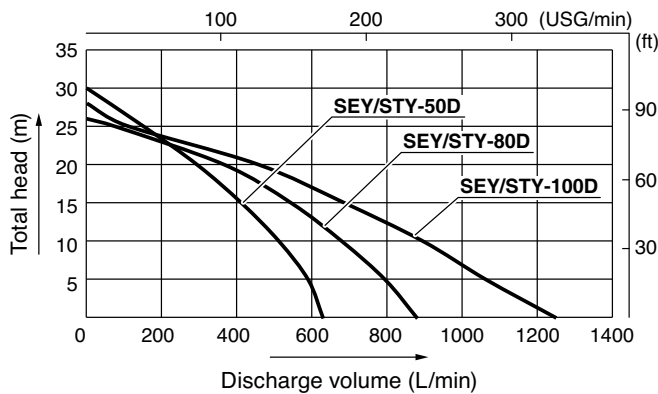

■ Trash pump (KTY series)

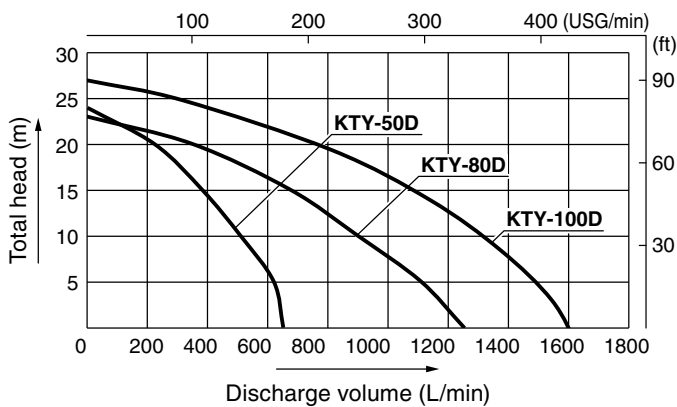

NOTICE

· Performance ratings are guaranteed minimum, not inflated maximum.

SPAREPARTS

SPAREPARTS

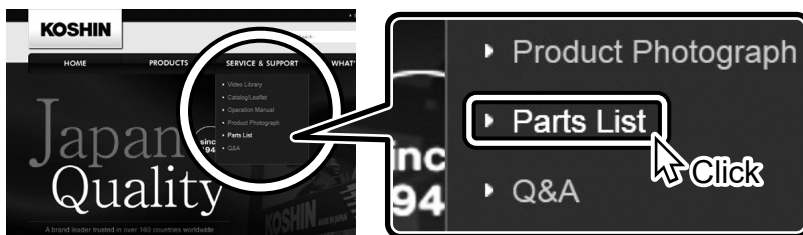

For spareparts information, visit



<http://www.koshinpump.com>

KOSHIN LTD.

www.koshinpump.com

TEL.: +81-75-953-2499 FAX.: +81-75-954-6119

E-mail: info@koshin-ltd.co.jp

12 Kami-Hachinotsubo Kotari, Nagaokakyo City,
Kyoto 617-8511 JAPAN